

# the Eliminator™ Product Data Sheet

The Eliminator 5000 is designed for simple installation inside a duct or plenum. This highly accurate Thermal Anemometer is factory calibrated and provides the user with a linear output signal for both air velocity and temperature. When combined with intelligent DDC systems, the *Eliminator* affords the engineer and building manager a cost effective tool for the accurate and reliable control necessary to meet the requirements of today's air distribution systems. Maintenance free and easy to install.

**Effective and Economical Measurement For:**

- Economy Fan Tracking
- Direct Measurement of Outdoor Air Intake Flow Rates (outside air temperatures greater than -20° F and less than 1500 FPM when remote electronics are exposed to ambient temperatures greater than 30° F)

**Features:**

- Microprocessor based electronics with “watchdog” timer circuitry to assure continuous operation after power resets and brownouts
- Low flow sensitivity, measures from 0 ft/min
- Each sensing point is independent
- True average velocity & temperature output
- Temperature compensated velocity output
- 1:1 isolation transformer assures a “floating” output to host control interface
- Optional offset/span allows for field adjustment



**Specifications**

PERFORMANCE		
Sensor Accuracy - Velocity		+/-2% of Reading
Sensor Accuracy - Temperature	typ.	0.18° F
	max.	0.36° F
Output Resolution		0.4% of F.S.
OUTPUT SIGNAL		
Velocity & Temperature	std.	linear 0-5 VDC
	opt.	linear 4-20mA
OUTPUT SCALING		
Velocity	std.	0-500 ft/min
		0-1000 ft/min
		0-2500 ft/min
		0-5000 ft/min
Temperature	std.	0°- 100° F
	opt.	Custom when ordered
POWER REQUIREMENT		
AC Power Input		24 VAC @ < 10 VA +/- 10%
OPERATING RANGES		
Operating Temperature Range [0-5000 fpm]		30° to 160° F
Operating Temperature Range [0-1500 fpm]		-20° to 160° F (sensor probe)
		30° to 160° F (remote electronics)
Operating Humidity Range		0 to 99% RH
PRESSURE DROP		
Pressure Drop @ 2000 ft/min	max.	0.005 in w.g.
CONSTRUCTION		
Sensors per Probe 51XX		1 to 4
Sensors per Probe 52XX		1 to 2
Probe Enclosure		Aluminum 5052
Probe Body		Aluminum 6063 T52
Sensor Housing		Glass Filled Polypropylene
Flow Sensor		Instrument Grade Thermistor
Temperature Sensor		Instrument Grade Thermistor

**Mechanical Construction**

- **Enclosure and cover [1]:** Stamped, 0.04", 5052 alloy, aluminum sheet and 6063-T52 extruded, non rated enclosure, access for two (2) 1/2" conduit connections
- **Support Bracket [2]:** Stamped, 0.04", 6063-T52 extruded alloy, aluminum
- **Support Bracket Hardware (to support strut) [3]:** 10-24-1.5", zinc plated steel bolt w/nylon insert stop nut and washers
- **Support Struts [4]:** Tubular, 6061-T6 extruded alloy, aluminum; 1.1" O.D.

**Sensor Construction**

- **Heated Velocity Sensor:** glass encapsulated, hermetically sealed, industrial grade thermistor probe
- **Temperature Sensor:** glass encapsulated, hermetically sealed, industrial grade thermistor probe
- **Sensor Housing:** Glass Filled Polypropylene
- **Sensor Assembly Compounds:** epoxy
- **Internal Wiring:** Kynar® coated copper

**Cable Assembly**

- **Cable [5]:** Plenum Rated PVC UL Standard 13, Type CL2P CSA PCC FT6, NEC Article 725 Passes Steiner Tunnel Test UL Listed, CSA Certified
- **Terminal Connectors at Electronics Enclosure [6]:** CPC Circular Connectors  
Models 5110 to 5130 - nominal diameter 0.92", 1 connector  
Model 5140 - nominal diameter 1.34", 1 connector  
Models 5210 and 5220 - nominal diameter 0.92", 2 connectors

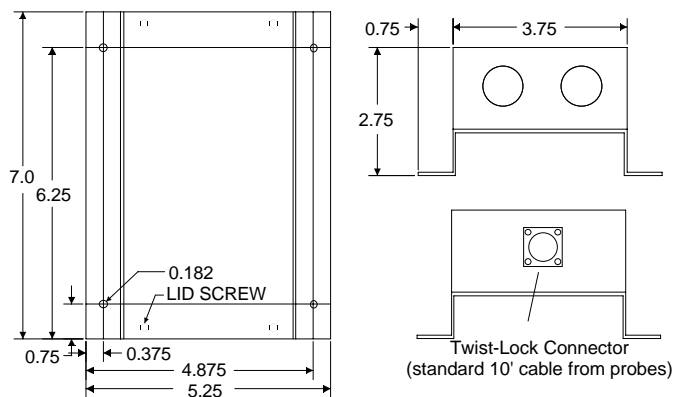

## Wiring

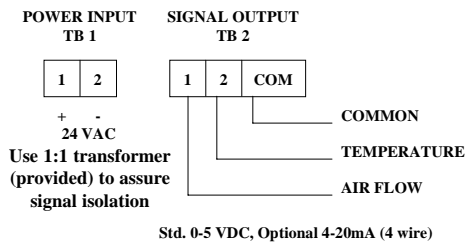

Model	VA
5110	6.6
5120	7.3
5130	7.9
5140	8.6
5210	7.3
5220	8.6

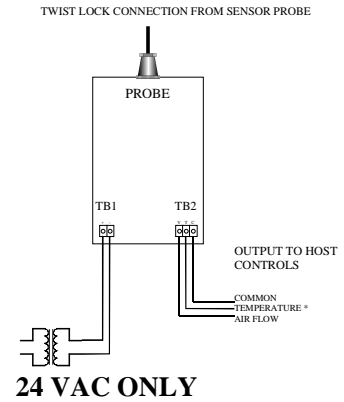

TERMINAL CONNECTIONS

POWER REQUIREMENTS

WIRING SCHEMATIC

## Installation

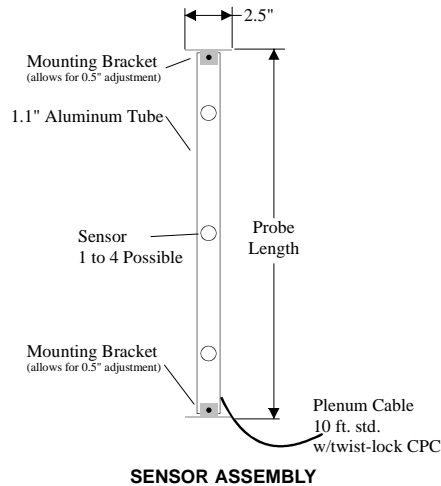

SENSOR ASSEMBLY

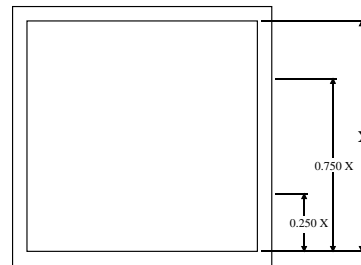

Number of Probes	Distance From Inside Edge of Duct	
	Probe 1	Probe 2
1	0.500 X	
2	0.250 X	0.750 X

INSTALLATION IN RECTANGULAR DUCTS

## Suggested Engineers Guide Specification

Insert under the airflow measurement heading in the Temperature Control Section of the Specification [optionally, 5000 sensors can also appear in the AHU section of the specification]

### A. Manufacturer

1. Base Bid: **EBTRON** Inc., Model 5000

B. Air Flow and Temperature Measurement: Thermal anemometer using instrument grade self heated thermistor sensors with thermistor temperature sensors. Flow measurement drift shall not exceed Manufacturers repeatability statement for the life of the equipment. Manufacturer shall provide test data for accuracy performance prior to bid date. Vortex shedding arrays are not acceptable. Pitot tube and differential pressure sensing arrays are not acceptable. Sensors requiring auto-zeroing are not acceptable.

1. **EBTRON** Model 5000 Duct Mounted Sensor

a) Flow Station Construction

(1) Type: Duct Mounted

(2) Sensors : One glass encapsulated self heated thermistor and one glass encapsulated thermistor temperature sensor for each sensing point.

(3) Sensor Housing: Noryl

(4) Sensors per probe: 1 to 4

(5) Support Struts: Extrusion Tubular Aluminum 6063-T6

(6) Supporting Bracket: Extrusion Aluminum 6063-T52

b) Electronics

(1) Type: Microprocessor Based, totally solid state.

(2) Power Requirement: 24 VAC. Multiple Series 5000 probes wired from a single transformer must be wired in phase.

(3) Enclosure: Aluminum, indoor use only. [option, insert: NEMA 4, outdoor use]

c) Performance

(1) Electronics temperature range: 30 to 160 F

(2) Flow station temperature range: 30 to 160 F (velocity up to 5000 FPM)

Flow station temperature range: -20 to 160 F (velocity <1500 FPM)

(3) Flow station velocity range: 0 to 5,000 ft./min.

(4) Flow station pressure drop: less than 0.005 inwc @ 2000 ft./min

(5) Flow station humidity range: 0 to 99% RH (non-condensing)

(6) Analog output signals: 0-5VDC [option 4-20mA, 4-wire]

(a) Sensor velocity accuracy: +2% reading

(b) Sensor temperature accuracy: typ. 0.18 F, max. 0.36 F

(c) Type: linear

(d) Repeatability: +- 0.2% scale

(e) Resolution: 0.4% scale

d) Warranty

(1) 36 months from shipment, parts and factory labor as described in the Company's Standard Terms & Conditions of Sale

## Ordering Information

5 a b c d x e f g h i j k l

a- Probes per electronics: 1 (2 on 5210 and 5220 only)

b- Sensors per Probe: 1 to 4

c- Adjustable airflow output: 0=no, 1\*=yes

d- Probe Length (inches)

e- Insertion Side Width of Duct (inches)

f- Internal Insulation (inches, each side of duct)

g- Shape and Material: 1=alum. rect.

h- Cable Length (feet, 10 ft. std., up to 25 ft.)

i- Input Power: 1=24 VAC, 2=110 VAC

j- Output Signals: 1=0-5 VDC airflow & temp., 3\*=4-20 mA airflow & 0-5 VDC temp., 4\*=4-20mA airflow & temp.

k- Airflow Signal Range, 0 to: 1=500 FPM, 2=1000 FPM, 3=2500 FPM, 4=5000 FPM, 6=Custom FPM, 7=Custom CFM

l- Temperature Signal Range: 1=30°-80°F, 2=Custom °F, 3=Custom °C

\* Optional configuration, may require additional charges

EBTRON, Inc., 1663 Hwy. 701 S., Loris, SC 29569

Phone: 1-800-2EBTRON (1-800-232-8766) 1-843-756-1828 FAX: 1-843-756-1838 Internet: www.ebtron.com